



Premium

Construction

The Premium architectural fixture is fabricated with a spun aluminum dome housing and a heavy-duty spun aluminum reflector with an outdoor polyester powder coat finish. Comes in 3 different sizes; 20" Dia. (PRE/PREGG-20), 24" Dia. (PRE/PREGG-24), and 30" Dia. (PRE/PREGG-30). The Premium aluminum dome-shaped weathertight aluminum housing is configured to be sleek with no windows or aluminum rings. The spun reflector has three (3) different styles; (Concave Shade (CCH), Convex Shade (CVH), and Straight Shade (SSH)) to meet a variety of different architectural requirements. Built to fit either a Side Arm Mount (SAM23806) or Top Arm Mount (TAMID138045 or TAMID163045) architectural arms for poles or walls.

Standard Height Fixtures (PRE-20/-24/-30)

Primarily for high mounting (12 ft or higher) applications, for wall and pole mount arms in commercial venues.

Low Height Glare Guard (GG) Fixtures (PREGG-20/-24/-30)

Primarily for low mounting (10 ft or less) applications, Zuma's Glare Guard (GG) design is ideal for wall and pole mount arms in commercial venues.

Electrical

- Watts : 20w through 180w
- Voltage: 120v through 277v (all wattages) or in High voltage 347V - 480V (from 60W - to 180W), Custom watts available, specify.

LED

High performance LED CRI: 80. Color temperature ranges from CCT: 2700K - 5000K. Also available in Amber +560nm (AMBR).

Optic

Type II (T2), Type III (T3), Type IV (T4), and Type V (T5)

Lens

- No Lens (NL): For Type II through Type IV (T2, T3, T4, T5) optics.
- Anti-Glare Frosted Diffusion Lens (FDL): For use with Type V (T5) optics only. Consult factory for Anti-Glare Frosted Diffusion Lens with other Optic Types - Type II through Type IV (T2, T3, T4, T5).

Mounting

- Side Arm Mount (SAM1). A side mount arm that fits over Architectural Arms (for pole or walls) with side mount code "SA2". Fixture(s): PRE/PREGG-18, PRE/PREGG-24 & PRE/PREGG-30.
- Top Arm Mount (TAM1). A top mount arm that fits over cast Aluminum Architectural Arms (for pole or walls) with top mount code "TA1". Fixture(s): PRE/PREGG-18, PRE/PREGG-24. & PRE/PREGG-30.
- Top Arm Mount (TAM2). A top mount arm that fits over Architectural Arms (for pole or walls) with top mount code "TA2". Fixture(s): PRE/PREGG-18 & PRE/PREGG-24.
- Top Arm Mount (TAM3). A top mount arm that fits over Architectural Arms (for pole or walls) with top mount code "TA3". Fixture(s): PRE/PREGG-30.

Finish

Outdoor polyester powder coat, available in our Zuma standard finishes with a four-step pretreat process to ensure optimal adhesion and surface integrity. Also available in custom RAL and in marine grade finish (MGF), specify.



Shade Style

- Concave Shade (CCH): Cupped shaped curved spun aluminum shade.
- Convex Shade (CVH): Spherical curved spun aluminum shade.
- Straight Shade (SSH): Cone shaped spun aluminum shade.

Controls

- Dimming. 0-10v dimming (D) available.
- Photocell (PC): Mounts to fixture top (for SAM1) or side (for TAM1) mounting.

Options

- Premier can be made to "Buy American Compliant" (BAA) and "Build America, Buy America Act Compliant" (BABA) (includes BAA)
- SKY = Sky Night Friendly: Downward light only.
- HSS = 180° House Side Shield.
- SP = Surge Protection: To be field installed in the bottom of the pole.
- Super Durable Marine Grade Finish (MGF) available in standard and custom colors, consult factory.

Certificates & Warranty

- Designed to comply with UL 8750
- Suitable for Wet Locations
- 5-Year Warranty

Technical

- Operating Temperature: -40°F to 95°F (-40°C to 35°C)

DISCLAIMER - The information provided in this document is subject to change without notice. Zuma Lighting reserves the right to modify product specifications and design at any time. Please consult with our representatives for the most current and accurate information.





ZUMALIGHTING

Project _____ Type _____ Qty _____

Company _____ Part # _____

Premium

Example Code: PRE-20-20W-U-3K-T2-TAM2-BZ8-D-BABA

Item	Wattage Lumens ¹	Volts	Color Temp	Optics	Lens	Mounting	Finish	Shade Style	Controls	Options
PRE-20 20" dia	20W 1960-2260	U 120v-277v	27K 2700K	T2 Type II	NL² No Lens	SAM1 Side Arm Mount	BZ8 Zuma Bronze	CCH Concave Shade	D Dimming 0-10v	BAA³ Buy American Act Compliant
PRE-24 24" dia	30W 2940-3390	HV 347v-480v	3K 3000K	T3 Type III	FDL⁴ Anti-Glare Frosted Diffusion Lens	TAM1 Top Arm Mount	BK GT Black	CVH Convex Shade	PC Photocell	BABA³ Build America, Buy America Act Compliant
PRE-30 30" dia	40W 2940-4520		35K 3500K	T4 Type IV		TAM2 Top Arm Mount	SL Iridium Silver	SSH Straight Shade		SKY Sky Night Friendly
PREGG-20 20" dia	60W 5880-6780		4K 4000K	T5 Type V		TAM3 Top Arm Mount	WH Alpine White			HSS 180° Houseside Shield
PREGG-24 24" dia	80W 7840-9040		45K 4500K				GRY Granite Gray			HSSOP 180° Houseside Shield (Optics)
PREGG-30 30" dia	90W 8820-10170		5K 5000K				GRN Moss Green			MGF Marine Grade Finish
	120W 11760-13560		AMBR⁵ 560nm+				CCxxx⁶ Custom Color			SP Surge Protection
	150W 14700-16950									
	160W 15680-18080									

- 1 Lumen values may vary based on factors such as distribution type and color temperature.
- 2 Fixtures specified without diffusion lens are equipped with exposed optical lens. For use with Type II through Type V (T2, T3, T4, T5) optics.
- 3 Consult our sales team for detailed information on compliance with domestic manufacturing regulations.
- 4 For use with Type V (T5) optics only. Consult factory for Anti-Glare Frosted Diffusion Lens with other Optic Types - Type II through Type IV (T2, T3, T4).
- 5 Amber lighting is for turtle and wildlife friendly requirements (560nm+) and lumen outputs will be reduced to approximately 40-50 lm/w.
- 6 Custom colors: Available in smooth and textured finishes. Also available in RAL and Sherwin Williams colors, consult factory.



DISCLAIMER - The information provided in this document is subject to change without notice. Zuma Lighting reserves the right to modify product specifications and design at any time. Please consult with our representatives for the most current and accurate information.



Premium

Dimensions

Premium - PRE & PREGG : Technical

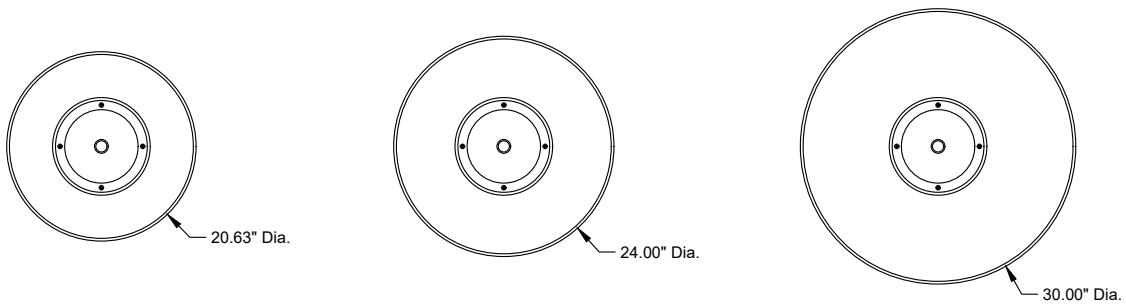

Straight Shade (SSH)

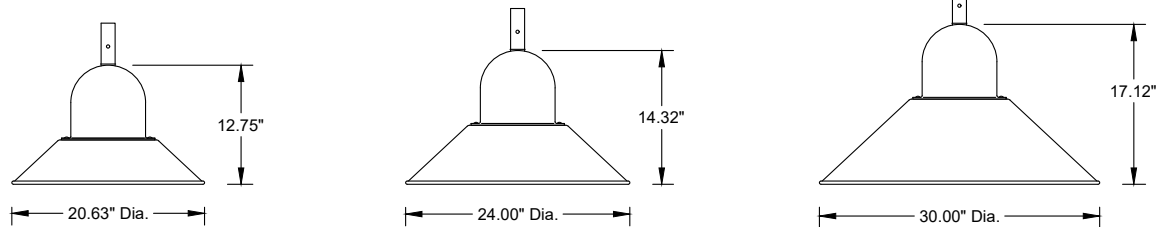

Convex Shade (CVH)

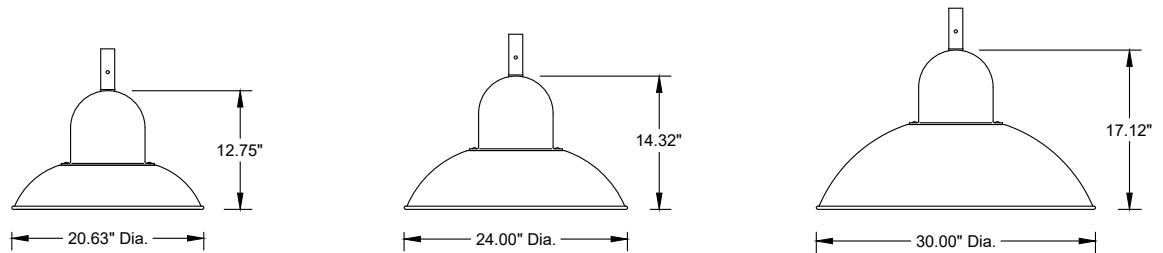

Concave Shade (CCH)

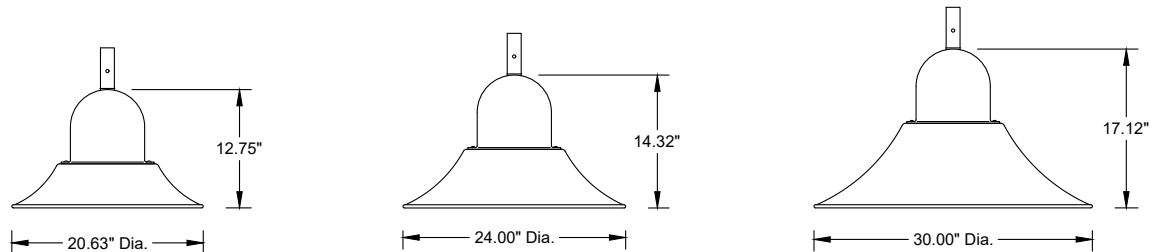

DISCLAIMER - The information provided in this document is subject to change without notice. Zuma Lighting reserves the right to modify product specifications and design at any time. Please consult with our representatives for the most current and accurate information.

